

- Several fixture distances available
- Simple, modular design
- Endless rotation

This is one station positioner for workpieces requiring rotation about one axis. It is equipped with a tailstock. The fixture discs on head- and tailstock has endless rotation.

Suitable for workpieces with a diameter up to 1500 mm.  
Maximum payload up to 500 kg.

**Available accessories**

- Fixture disc for the tailstock
- Fixture brackets

**Options**

- Slip ring device
- Controlled air

Technical data		HSD-250 SDM	HSD-500 SDM
Maximum payload	kg	250	500
Welding capacity, 100% duty cycle	A	350	350
Welding capacity, 60% duty cycle	A	460	460
Weight	kg	310-350	320-360
Distance between fixture plates (L)	mm	1600, 2000, 2500	1600, 2000, 2500
Maximum fixture's width, diameter (D)	mm	1500	1500
Height to fixture disc's centre (H)	mm	1020	1020
<i>Rotating axis</i>			
Torque, dynamic	Nm	393	608
Torque, static	Nm	314	486
Rated speed	rpm	0-22.5	0-16.8
Maximum speed	rpm	37	44.3
Axis' rotation		Endless	Endless
Rated offset from COG	mm	128	100

# HSD

Light series (M)

1-station

## HSD-250 SDM, HSD-500 SDM

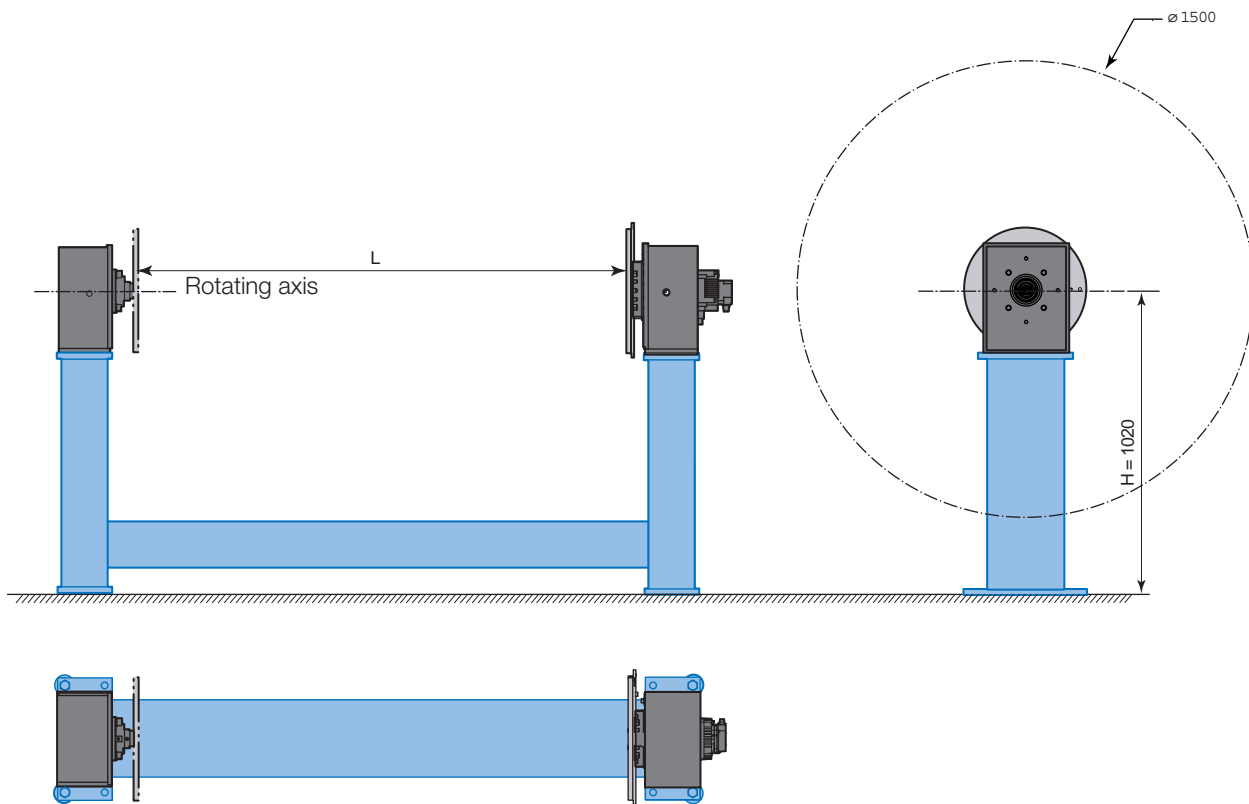

Technical data may be subject to change without previous notice  
© YASKAWA Nordic AB - Reg No. 1052EN-02 - 2012-03