

GP12, GP25 and GP25-12

Increase Productivity

Highest payloads, speeds and wrist allowable moment in its class

- The productivity of the customer's equipment can be improved with the highest speed in the 12 and 25 kg payload class
- Acceleration/deceleration control has been improved to achieve maximum reduction of acceleration/deceleration times for all robot postures

Maximum speed has been increased 15% (max.) in comparison to the former model



Hollow arm



50 mm dia.



50 mm dia.

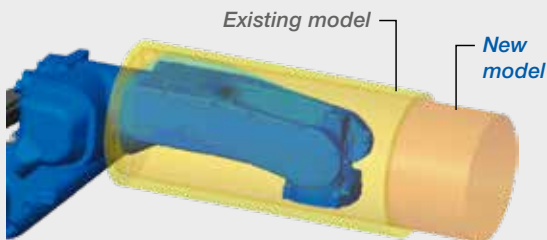

Minimized interference radius of the wrist
 MH12/MH24 (earlier models): 136/147 mm
 GP12/GP25 (new models): 120/138 mm

Make Equipment compact

Easy-to-use structure

- The hollow arm structure to store cables reduces operation restriction due to cable interference, simplifies teaching and eliminates cable disconnection caused by interference

Best accessibility in its class

- The slim arm design minimizes interference with peripheral devices even in small spaces

Improve Efficiency in Installation, Operation and Maintenance of Equipment

Easy set-up

- Only one cable is required, which reduces setup time

Wrist structure with great environment resistance

- Wrist structure of R, B and T axes are IP67-compliant as a standard specification
- Wrist structure of S, L and U axes are IP54-compliant (option IP65)

Easy maintenance

- Data saving feature enables to replace the wire harness in the robot without having to connect to a battery
- Productivity improvement due to reduction in number of cables & connectors



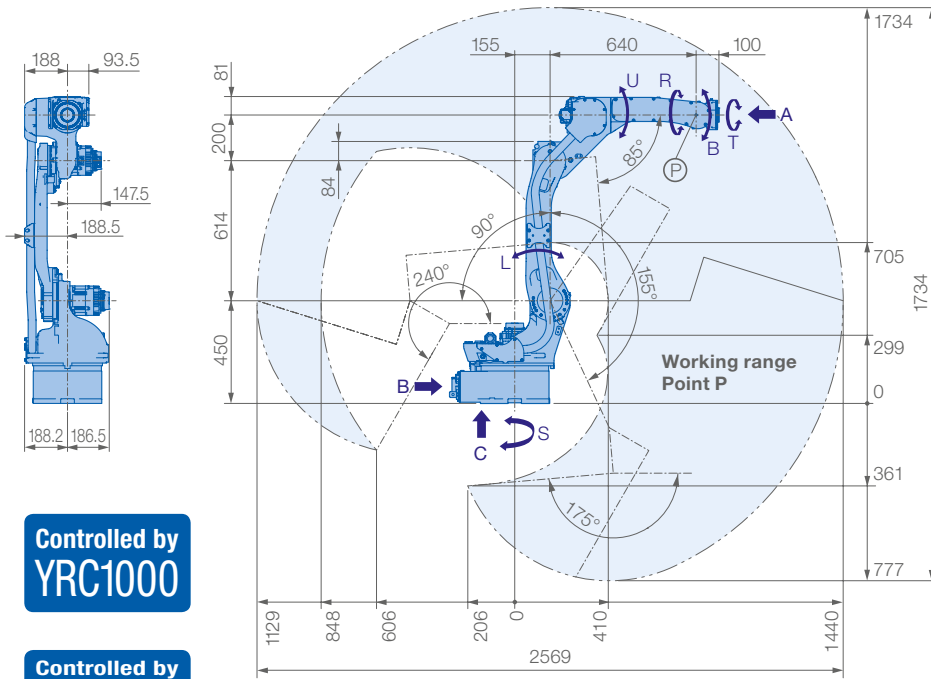

View A

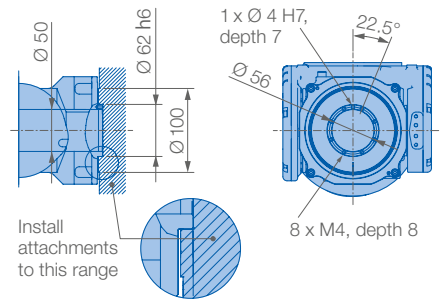

View B

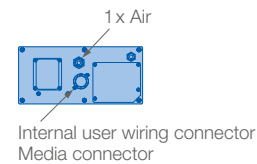

View C

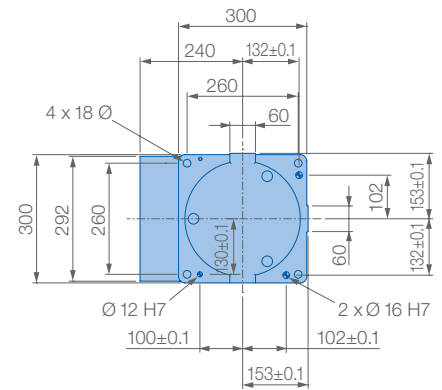

Mounting options: Floor, ceiling, wall, tilt*

Protection class: Main axes (S, L, U) IP54 (option 65), wrist IP67

* tilt with condition of angle – see table below

Prevent interaction of the robot with:

- Corrosive gases, liquids or explosive gases
- Exposure to water, oil or dust
- Excessive electrical noise (plasma)



Allowable wrist load

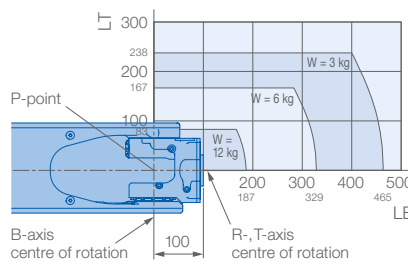

Robot installation angle θ [deg.]	S-axis operating range [deg.]
$0 \leq \theta \leq 30$	± 170 degrees or less (no limit)
$30 < \theta \leq 35$	± 60 degrees or less
$35 < \theta \leq 45$	± 45 degrees or less
$45 < \theta$	± 30 degrees or less

Specifications GP12

Axes	Maximum motion range [°]	Maximum speed [°/sec.]	Allowable moment [Nm]	Allowable moment of inertia [kg · m ²]	Controlled axes	6
S	± 170	260	–	–	Max. payload [kg]	12
L	+155/–90	230	–	–	Repeatability [mm]	$\pm 0.08^*$
U	+155/–85	260	–	–	Max. working range R [mm]	1440
R	± 200	470	22	0.65	Temperature [°C]	0 to +45
B	± 150	470	22	0.65	Humidity [%]	20 – 80
T	± 455	700	9.8	0.17	Weight [kg]	150
					Power supply, average [KVA]	1.5**

* Conforms to ISO 9283 ** Varies in accordance with applications and motion patterns **Note:** SI units are used for specifications.

All dimensions in mm